

Specifications

Telescopic Boom All Terrain Crane

ATC-3130

130-ton (118 metric tons)

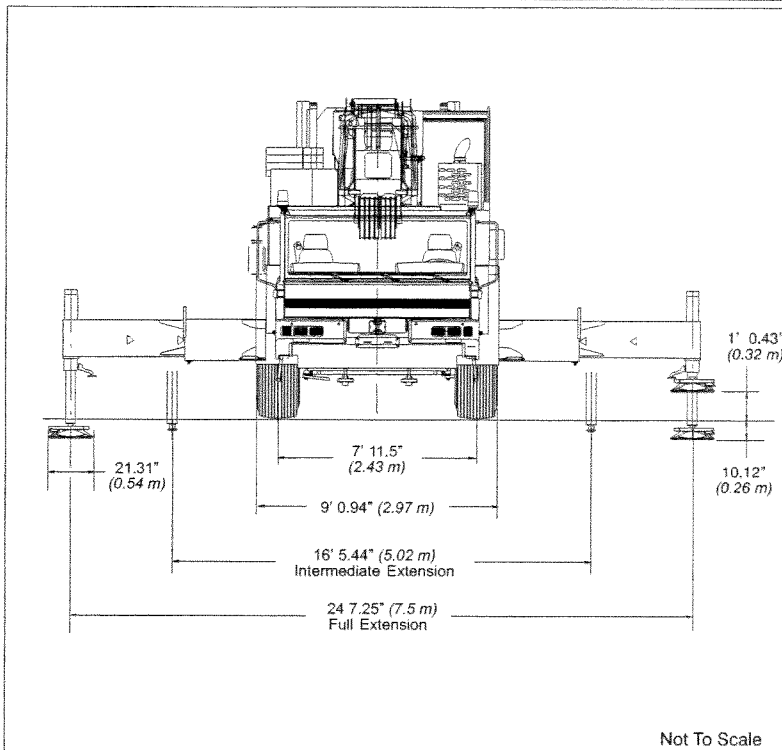
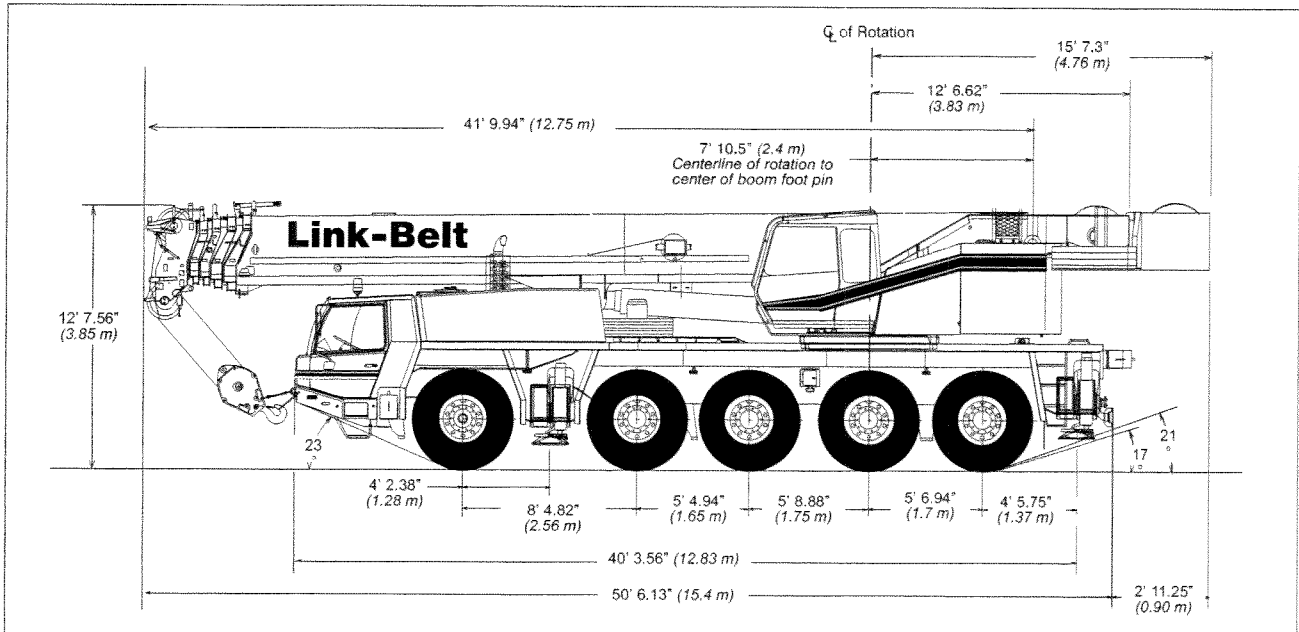

Turning Radius – Front Wheel (10 x 6)

Steering	feet	meters
Carrier inside	25' 3.13"	7.7
Wall to wall over carrier	45' 3.31"	13.8
Wall to wall over boom	48' 10.63"	14.9
Wall to wall over boom extension	51' 2.19"	15.6
Centerline of tire	40' 4.25"	12.3

Turning Radius – All Wheel (10 x 10)

Steering	feet	meters
Carrier inside	14' 1.31"	4.3
Wall to wall over carrier	33' 5.56"	10.2
Wall to wall over boom	37' 8.75"	11.5
Wall to wall over boom extension	39' 8.38"	12.1
Centerline of tire	28' 2.56"	8.6

Tailswing

	feet	meters
with auxiliary winch	16' 0"	4.9
without auxiliary winch	13' 3.25"	4.1

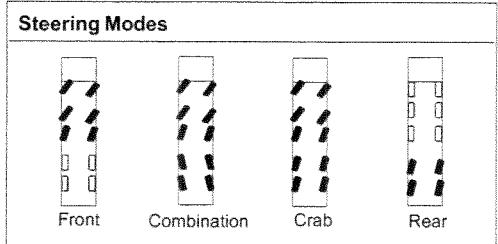

Boom, Attachments, Upper Structure

■ Boom

Boom Design – Five section, formed box type construction of high tensile steel consisting of one base section and four telescoping sections. The first and second telescoping sections extend independently by means of one double acting, two stage hydraulic cylinder with integrated holding valves. The third and fourth telescoping sections extend proportionally by means of one double acting, single stage cylinder with integrated holding valves and cables.

Boom

- 42' – 167' 4" (12.8 – 51.0 m) five-section full power boom.
- Three mode boom extension by automatic locking of the first telescope section (0%, 50% & 100%) controlled from operator's cab.
- Telescope overrides allow all sections to be telescoped independently.
- Two speed extension: normal – 200 seconds / high – 140 seconds
- Mechanical boom angle indicator
- Wind speed indicator
- Maximum sheave height is 177' 2" (54 m).

Boom Head

- Seven 18.19" (46.2 cm) root diameter nylon sheaves to handle up to fourteen parts of line.
- Easily removable wire rope guards.
- Rope dead end lugs on one side of the boom head.
- Boom head is designed for quick reeve of the hook block.

Boom Elevation

- One double acting hydraulic cylinder with integral holding valve.
- Two speed boom up: normal – 86 seconds / high – 50 seconds.
- Boom elevation: –2° to 82°

Auxiliary Lifting Sheave – Optional

- Single 18.19" (46.2 cm) root diameter nylon sheave (stowable).
- Easily removable wire rope guards.
- Does not affect erection of the fly or use of the main head sheaves

Hook Blocks and Ball – Optional

- 27.6-ton (25 mt) 1-sheave quick-reeve hook block with safety latch
- 69.4-ton (63 mt) 3-sheave quick-reeve hook block with safety latch
- 130-ton (117.9 mt) 7-sheave quick-reeve hook block with safety latch
- 8.8-ton (8.0 mt) swivel hook ball with safety latch

Fly – Optional

- 31.1' – 53.2' (9.5 – 16.2 m) two piece telescoping lattice fly, stowable, offsettable to 5°, 20° and 40°.
- 24.6 ft (7.5 m) tubular jib extension giving a total extension length of 79.1' (24.1 m).

- 19.7 ft (6.0 m) tubular jib extension giving a total extension length of 98.8' (30.1 m).

■ Cab and Controls

Cab – Spacious all steel construction with acoustical fabric insulation. The cab equipped with the following features:

- Tiltable up to 20°.
- Sliding left side door.
- Extra-large tinted glass windows.
- Fold-out front window with windshield washer and wiper.
- Fixed cab roof with armored glass and windshield washer/wiper.
- Six way adjustable, hydraulically cushioned seat with headrest.
- Diesel powered heater and air conditioning
- Engine dependent warm-water heater with defroster nozzles for windshield and cab floor
- 12-volt connection.
- Adjustable sun visor.
- Dome light.
- AM/FM radio with cassette
- Warning horn
- Fire extinguisher

Controls – Two dual axis electronic joystick controllers for:

- Swing
- Boom hoist
- Boom Telescope
- Main front winch
- Auxiliary rear winch – optional
- Counterweight removal
- Cab tilting
- Two speed function
- Drum rotation indication
- Free swing (automatic brake)

Dash mounted controls and indicators for:

- Travel controls for steering and driving in first forward and reverse gear only.
- Outrigger controls
- Emergency shut down
- Battery main shutoff
- Front and rear windshield wipers and washers
- Boom and cab floodlights
- Carrier throttle
- Carrier service brakes and air pressure readout
- Carrier turn indicators
- Air conditioning and fan speed controls
- Carrier transmission control
- Carrier and upper ignition

Foot controls for:

- Horn
- Carrier service brakes
- Swing brake
- Engine throttle

Cab Instrumentation – Ergonomically positioned digital instrumentation for crane operation including:

- Engine coolant temperature

- Electronic bubble level and levelness readout
- Suspension and house lock indicator
- Hydraulic oil and air cleaner filter indicator
- Hydraulic oil temperature
- Outrigger force readout
- Low engine oil indicator
- Low voltage indicator
- Fuel level
- Engine hourmeter and clock

Rated Capacity Limiter – PAT DS350

Graphic audio-visual warning system built into the dash with anti-two block and function limiter. Operating data available includes:

- Machine configuration
- Boom length and angle
- Head height
- Allowed load and % of allowed load
- Boom angle
- Radius of load
- Actual load
- Wind speed

Presetable defined area alarms include:

- Maximum and minimum boom angles
- Maximum tip height
- Maximum boom length
- Swing left/right positions

■ Swing

Bi-directional hydraulic swing motor mounted to a planetary reducer for 360° continuous smooth swing at 1.5 rpm

Swing park brake – 360°, electric over hydraulic, (spring applied/hydraulic release) multi-disc brake mounted on the speed reducer. Operated by a rocker switch from the operator's cab.

Swing brake – 360°, foot operated, hydraulic applied disc brake mounted to the speed reducer.

Swing lock – One position house lock (boom over rear) operated from the operator's cab.

360° positive swing lock – optional meets New York City requirement.

■ Hydraulic System

Main Pumps

- Two variable displacement piston pumps for the main and auxiliary winches, boom hoist and telescope.
- One fixed displacement piston pump for the counterweight removal, telescope pinning, tilting cab and swing.
- One fixed displacement gear pump for pilot pressure.
- One fixed displacement gear pump for air conditioning
- The upper engine powers the pumps. Combined pump capacity of 145.3 gpm (550 lpm).
- Hydraulic oil cooler.

Boom, Attachments, Upper Structure – (continued)

Pump Control “Fine Inching” Mode – Special fine metering pump settings, selectable from the operator’s cab, allows very slow movements to the main and auxiliary winches, boom hoist, telescope and swing for precision work.

Pump Control “High Speed” Mode – Boosts hydraulic oil flow by combining the two variable displacement piston pumps for the main and auxiliary winches, boom hoist up and telescope extend. Operated by a button on either joystick controller from the operator’s cab.

Hydraulic Reservoir – 268 gallons (1 020 L) capacity equipped with sight level gauge. Diffusers built in for deaeration.

Filtration – One 12 micron, full flow, line filter in the control circuit. All oil is filtered prior to return to sump tank. Accessible filter for easy replacement.

Counterbalance Valves – All hoist motors are equipped with counterbalance valves to provide load lowering and prevents accidental load drop when hydraulic power is suddenly reduced.

Boom Hoist Float Valve – For transporting the boom over the rear of the crane with a boom dolly. Allows hydraulic oil within the boom hoist cylinder to flow between piston side and case side.

Swing Brake Release Valves – For transporting the boom over the rear of the crane with a boom dolly. Holds the 360° swing park brake in the release position allowing free rotation of the upperstructure.

■ Pump Drive

All functions are hydraulically powered allowing positive, precise control with independent or simultaneous operation of all functions.

■ Electrical

Two batteries provide 24-volt operation and starting.

Swing Alarm – Audio/visual warning device signals when the upper is swinging.

Lights

- One rotating beacon on right-side of main winch.
- Two working lights on cab front.
- One working light on the boom base section.
- Two side marker lights on boom head.

■ Fuel Tank

- One 79.2 gallon (300 L) capacity tank.

■ Engine

Specification	Mercedes Benz OM 904 LA
Number of cylinders:	4
Cycle:	4
Bore:	4.02 in. (102 mm)
Stroke:	5.12 in. (130 mm)
Displacement:	259.35 cu. in. (4 250 cm ³)
Maximum brake hp:	170 (125 kW) @ 2,300 rpm
Peak torque (ft. lb.):	487 (660 J) @ 1,200 rpm
Alternator volts / amps:	24 volts / 90 amps
Crankcase capacity:	16.91 qts. (16 L)

- Engine pre-heat system.

■ Load Hoist Performance

Main (Front) and Auxiliary (Rear) Winches – 0.83” (21 mm) Rope										
Layer	Maximum Line Pull		Normal Line Speed		High Line Speed		Layer		Total	
	lbs.	kg	ft/min.	m/min.	ft/min.	m/min.	ft.	m	ft.	m
1	20,457	9 279	191	58.2	341	103.9	169	51.5	169	51.5
2	18,996	8 616	206	62.8	367	111.9	182	55.5	351	107.0
3	17,729	8 042	221	67.4	394	120.1	195	59.4	546	166.4
4	16,621	7 539	236	71.9	419	127.7	208	63.4	753	229.5
5	15,644	7 096	250	76.2	446	135.9	221	67.4	974	296.9
6	14,775	6 702	265	80.8	472	143.9	234	71.3	1,208	368.2
7	13,997	6 349	280	85.3	499	152.1	247	75.3	1,455	443.5

Wire Rope Application	Diameter		Type	Max. Permissible Load	
	in.	mm		lbs.	kg
Main (Front) Winch	0.83	21	35 x 7 rotation resistant – 1,770 N/mm ² – right lang lay	16,680	7 565.9
Auxiliary (Rear) Winch	0.83	21	35 x 7 rotation resistant – 1,770 N/mm ² – right lang lay	16,680	7 565.9

■ Load Hoist System

Main and Auxiliary (Optional) Winches

- Axial piston, constant displacement motor driven through planetary reduction unit for positive control under all load conditions.
- Grooved lagging.
- Power up/down mode of operation.
- Third wrap indicator with function lockout.
- Drum rotation indicator
- Wire rope with “Superstop” easy reeving system.
- Drum diameter: 20.67” (525 mm)
- Rope diameter: 0.83” (21 mm)
- Rope length: 820’ (250 m)

Counterweight

Standard – Total of 30,864 lbs. (14 000 kg), modular design, assembled and disassembled by hydraulic cylinders controlled from operator's cab.

Optional – 24,251 lbs. (11 000 kg) in addition to standard counterweight for a total of 55,115 lbs. (25 000 kg).

Counterweight Combinations	Standard		Optional	
	0 lbs. (0 kg)	30,864 lbs. (14 000 kg)	47,178 lbs. (21 400 kg)	55,115 lbs. (25 000 kg)
1 or Auxiliary (Rear) Winch		X	X	X
2, 3, and 4		X	X	X
5		X	X	X
6			X	X
7				X
8		X	X	X
9		X	X	X
10		X	X	X
11		X	X	X

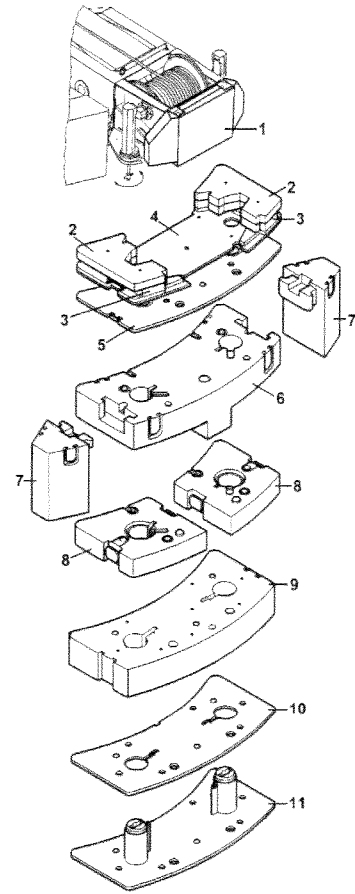

CARRIER

General

9' – 8.94" (2.97 m) wide. 349.58" (8.88 m) wheelbase (centerline of first axle to fifth axle).

Frame – box-type, torsion resistant, welded construction made of high tensile steel. Equipped with front and rear towing and tie-down lugs, tow connections and access ladders.

Outriggers

Boxes – Two double box, front and rear welded to the carrier frame.

Beams and Jacks – Four dual stage beams with Confined Area Lifting Capacities (CALC™) provides selectable outrigger extensions of full and intermediate positions. Hydraulically controlled from the operator's cab and on both sides of carrier. Each jack cylinder is equipped with integral holding valves.

Pontoons – Quick release "stow 'n go" 21.3 inch (542 mm) square nylon pontoons can be stored on the outrigger jacks for road travel.

Jacks Reactions – 163,000 lbs. (73 936 kg) force and 359.3 PSI (2 477.3 kPa) ground bearing pressure.

Steering and Axles

ZF semi-block dual circuit hydraulic steering, mechanical steering of three front axles with hydraulic booster. Rear axle steering mechanically locked in "centered" position. In 1st and reverse gears, rear axles can be hydraulically steered independently from the front axles or in combination with the front axles.

Emergency Steering – A pump is flange-mounted to the transfer box that provides hydraulic pressure to the steering circuit as long as the crane is in motion above 1.85 mph (3 km/h).

Drive – 10 x 6 for on-highway: 2nd, 4th and 5th axles are driven. 10 x 8 for off-highway travel: 2nd, 3rd, 4th and 5th axle are driven.

Axle 1 – Steered, non-driven

Axles 2 and 3 – Steered, driven with reduction: 9.72

Axle 4 – Steered, driven with reduction: 9.72, with integrated transfer case with reduction: 1.03

Axle 5 – Steered, driven with reduction: 9.72

Inter-Axle Differential Lock – Traction adding device that locks axles 2 and 3 with axles 4 and 5. Operated by a rocker switch from the carrier cab.

Transverse (Cross-Axle) Differential Locks – Traction adding device that locks differentials within axles 2, 3, 4 and 5. Operated by a rocker switch from the carrier cab with a 10 second timer.

Suspension

Hydro-pneumatic, lockable with level adjustment. All axles have longitudinal and transverse trailing arms. With leveling adjustment and locked cylinders, the chassis can be tilted laterally and longitudinally by push buttons in the carrier cab which adjust each individual suspension cylinder.

- Cylinder stroke: -4.94" (-126 mm) to +5.81" (+148 mm)

■ Tires and Wheels

- Ten, 20.5R25 on / off-road profile tires on steel disc wheels.

■ Brakes

Service – Full air brakes on all wheel ends. Dual circuit compressed air system with air dryer.

Parking/Emergency – Spring loaded type, acting on 3rd, 4th and 5th axles.

■ Electrical

Two batteries provide 24-volt operation and starting.

Lights

- Front lighting includes two main headlights, two high beams lights, two fog lights, two directional indicators and two parking lights.
- Rear lighting includes two rear combination panels each with directional indicator, parking light, brake light, for light, reversing light, and license plate light.
- Other equipment includes hazard warning system, cab light, instrument panel light, signal horn, and two amber rotating beacon on cab roof.

■ Engine

Specification	Mercedes Benz OM 502 LA
Number of cylinders:	8
Cycle:	4
Bore:	5.12 in. (130 mm)
Stroke:	5.91 in. (150 mm)
Displacement:	972.04 in ³ . (15 929 cm ³)
Maximum brake hp :	476 (355 kW) @ 2,000 rpm
Peak torque (ft. lb.):	1,548 (2 100 J) @ 1,080 rpm
Alternator: volts / amps	24 volts / 300 amps
Crankcase capacity	42.27 qts. (40 L)

- Engine pre-heat system.
- Engine exhaust brake.
- Constant throttle engine brake system.
- Hydro-statically driven fan and thermostatically controlled radiator.

■ Transmission

Automatic – Allison HD4560P with 6 forwards gears and 1 reverse gear.

Auxiliary – Steyr VG1600 two-stage transfer case with on/off highway gearing.

■ Fuel Tank

- One 132 gallon (500 liter) capacity tank

■ Hydraulic System

Main Pumps

- One variable displacement piston pump for the suspension and outriggers.
- Two, fixed displacement gear pumps for steering.
- One fixed displacement gear pump for emergency steering.
- The carrier engine powers the pumps. Combined pump capacity of 84.5 gpm (320 lpm).

Hydraulic Reservoir – 66 gallons (250 L) capacity equipped with sight level gauge. Diffusers built in for deaeration.

Filtration – Two 12 micron, full flow, line filter in the control circuit. All oil is filtered prior to return to sump tank. Accessible filter for easy replacement.

■ Cab and Controls

Cab – Fully enclosed, two person full width cab of composite structure with acoustical insulation.

Equipped with:

- Windshield with laminated safety glass with windshield wiper and washer.
- Slide side windows of hardened glass.
- Six-way adjustable and air suspended driver and passenger seats with integrated three point safety belts and headrests.
- Two electrically adjustable rear-view mirrors
- One wide angle mirror and additional turn mirror. (All mirrors are heated)
- Engine dependent warm-water heater with defroster nozzles for windshield and cab floor.
- AM/FM radio with cassette.
- Adjustable sun visor.
- Dome light.
- 12 volt connection.
- Air conditioning.
- Fire extinguisher.

Cab Instrumentation – Ergonomically positioned digital instrumentation for driving including:

- Speedometer with odometer
- Tachometer with hourmeter and clock
- Engine coolant temperature
- Transmission oil temperature
- Front and rear air pressure
- Drive modes (third axle, inter axle lock & cross axle locks)

- Rear axle and suspension lock indicator
- Suspension leveled indicator
- Steering malfunction indicator
- Emergency steering indicator
- High/low range indicator
- Low hydraulic oil indicator
- Air cleaner filter indicator
- Carrier/upper operation indicator
- Low engine oil indicator
- Low voltage indicator
- Fuel level

Dash mounted controls and indicators for:

- Battery main shutoff
- Windshield wipers and washers
- Carrier throttle
- Carrier lights and turn indicators
- Air conditioning and fan speed
- Transmission controls
- High/low range
- 3rd axle drive, inter axle lock and differential lock
- Carrier/upper control
- Suspension controls
- Carrier and upper ignition
- Park brake
- Mirror adjustments
- Warning lamps

Foot controls for:

- Carrier service brakes
- Engine throttle

■ Additional Equipment

Standard:

- Pneumatic and electrical quick disconnect connectors mounted on the rear bumper for boom dolly brakes and lights.
- Emergency function overrides
- Aluminum full deck fenders and ladders
- Hook block and ball bumper tie backs
- Hook ball storage
- Folding ladder (stowed under the carrier cab)
- Handling slings
- Mudflaps
- Tool box with tools
- Grease gun
- Medical kit
- Wheel chocks
- Tire inflation system
- Battery jumper cables

Optional:

- Spare 20.5R25 tire and wheel

■ **Carrier Speeds**

Allison HD4560P			Steyr VG 1600			
			High (1.54)		Low (0.89)	
Gear		Ratio	mph	km/h	mph	km/h
6th	Lock Up	0.67	49.7	80		
5th		0.76	49.7	80		
4th		1.00	37.9	61		
3rd		1.63	24.8	40	14.2	23
2nd		2.21	17.3	28	9.9	16
1st	Converter	4.70	8.0	13	4.9	8
1st		6.8	11	3.7	6	
Reverse		5.55	5.5	9	3.1	5
1st @ 800 rpm		4.70	3.1	5.2	1.6	2.6
Reverse @ 800 rpm		5.55	2.2	3.6	1.2	2.0

■ **Axle Loads (Without Boom Dolly)**

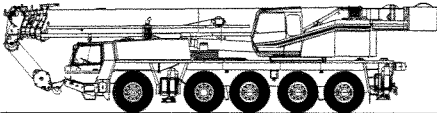

	GVW		Axle 1		Axle 2		Axle 3		Axle 4		Axle 5	
	lbs	kg	lbs	kg	lbs	kg	lbs	kg	lbs	kg	lbs	kg
Base machine with 0 lbs. of counterweight	116,363	52,781	24,603	11,160	24,603	11,160	22,386	10,154	22,386	10,154	22,386	10,154
Driver in the carrier cab	200	91	151	68	151	68	-34	-15	-34	-15	-34	-15
Auxiliary winch with 820' (250 m) of 7/8" (21 mm) rope	3,176	1,441	-1,458	-661	-1,458	-661	2,031	921	2,031	921	2,031	921
360° degree mechanical swing lock (New York City requirement)	51	23	5	-2	5	-2	13	6	13	6	13	6
(1) counterweight 2,205 lbs. (1,000 kg) on upper replaces auxiliary winch	2,172	985	-927	-420	-927	-420	1,342	609	1,342	609	1,342	609
(2), (3) and (4) counterweight 5,512 lbs. (2,500 kg) on upper	5,507	2,498	-2,262	-1,026	-2,262	-1,026	3,344	1,517	3,344	1,517	3,344	1,517
(5) counterweight 1,984 lbs. (900 kg) on upper - requires counterweight (4)	1,984	900	-728	-330	-728	-330	1,147	520	1,147	520	1,147	520
(6) counterweight 16,314 lbs. (7,400 kg) on upper - requires counterweight (8)	15,873	7,200	-5,842	-2,650	-5,842	-2,650	9,186	4,167	9,186	4,167	9,186	4,167
(7) counterweight 7,938 lbs. (3,600 kg) - requires counterweight (6)	7,937	3,600	-2,913	-1,321	-2,913	-1,321	4,587	2,081	4,587	2,081	4,587	2,081
(8) counterweight 8,820 lbs. (4,000 kg) - requires counterweight (11)	8,686	3,940	-3,169	-1,437	-3,169	-1,437	5,008	2,272	5,008	2,272	5,008	2,272
(9) counterweight 7,940 lbs. (3,600 kg) on upper - requires counterweight (11)	7,893	3,580	-2,896	-1,314	-2,896	-1,314	4,562	2,069	4,562	2,069	4,562	2,069
(10) counterweight 1,985 lbs. (900 kg) on upper - requires counterweight (11)	1,874	850	-688	-312	-688	-312	1,083	491	1,083	491	1,083	491
(11) counterweight 2,425 lbs. (1,100 kg) on upper	2,498	1,133	-917	-416	-917	-416	1,444	655	1,444	655	1,444	655
31.17 - 53.15' (9.5 - 16.2 m) offsettable, two-piece (telescopic) lattice fly	3,688	1,673	2,465	1,118	2,465	1,118	-414	-188	-414	-188	-414	-188
Auxiliary lifting sheave	232	105	254	115	254	115	-92	-42	-92	-42	-92	-42
69.4-ton (63 mt) three-sheave, quick-reeve hookblock with safety latch (stowed at boom head)	1,323	600	1,459	662	1,459	662	-532	-241	-532	-241	-532	-241
8.8-ton (8 mt) swivel hookball with safety latch (stowed in carrier storage)	440	181	208	94	208	94	8	4	8	4	8	4

■ Axle Loads (With Boom Dolly)

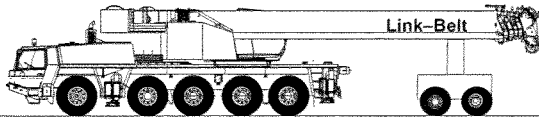

	GVW		Axle 1		Axle 2		Axle 3		Axle 4		Axle 5		Dolly	
	lbs	kg	lbs	kg	lbs	kg	lbs	kg	lbs	kg	lbs	kg	lbs	kg
Base machine with 0 lbs. (0 kg) of counterweight	116,363	52 781	19,331	8 768	19,331	8 768	18,509	8 768	18,509	8 768	18,509	8 768	22,175	10 058
Spare tire and steel disc wheel – 20.5R25 (without mounting bracket)	814	369	0	0	0	0	0	0	0	0	0	0	814	369
Driver in the carrier cab	200	91	151	68	151	68	-34	-15	-34	-15	-34	-15	0	0
Auxiliary winch with 820' (250 m) of 7/8" (21 mm) rope	3,176	1 441	1,441	653	1,441	653	98	44	98	44	98	44	0	0
360° degree mechanical swing lock (New York City requirement)	51	23	-6	-3	-6	-3	21	10	21	10	21	10	0	0
(1) counterweight 2,205 lbs. (1 000 kg) on upper replaces auxiliary winch	2,172	985	915	415	915	415	114	52	114	52	114	52	0	0
(2), (3) and (4) counterweight 5,512 lbs. (2 500 kg) on upper	5,507	2 498	2,232	1 012	2,232	1 012	348	158	348	158	348	158	0	0
(5) counterweight 1,984 lbs. (900 kg) on upper – requires counterweight (4)	1,984	900	718	325	718	325	183	83	183	83	183	83	0	0
(6) counterweight 16,314 lbs (7 400 kg) on upper – requires counterweight (8)	15,873	7 200	5,757	2 611	5,757	2 611	1,453	659	1,453	659	1 453	659	0	0
(7) counterweight 7,938 lbs. (3 600 kg) – requires counterweight (6)	7,937	3 600	2,870	1 302	2,870	1 302	732	332	732	332	732	332	0	0
(8) counterweight 8,820 lbs. (4 000 kg) – requires counterweight (11)	8,686	3 940	3,123	1 417	3,123	1 417	814	369	814	369	814	369	0	0
(9) counterweight 7,940 lbs. (3 600 kg) on upper – requires counterweight (11)	7,893	3 580	2,854	1 295	2,854	1 295	728	330	728	330	728	330	0	0
(10) counterweight 1,985 lbs. (900 kg) on upper – requires counterweight (11)	1,874	850	678	308	678	308	173	78	173	78	173	78	0	0
(11) Counterweight 2,425 lbs. (1 100 kg) on upper	2,498	1 133	903	410	903	410	230	104	230	104	230	104	0	0
31.17 – 53.15' (9.5 – 16.2 m) offsettable, two-piece (telescopic) lattice fly	3,688	1 673	119	54	119	54	77	35	77	35	77	35	3,219	1 460
Auxiliary lifting sheave	232	105	-16	-7	-16	-7	-10	-5	-10	-5	-10	-5	296	134
69.4-ton (63 mt) three-sheave, quick-reeve hookblock with safety latch (stowed at boom head)	1,323	600	-95	-43	-95	-43	-61	-28	-61	-28	-61	-28	1,696	769
8.8-ton (8 mt) swivel hookball with safety latch (stowed in carrier storage)	440	181	208	94	208	94	8	4	8	4	8	4	0	0
2-axle boom dolly	5,500	2 495	0	0	0	0	0	0	0	0	0	0	5,500	2 495
3-axle boom dolly	7,800	3 538	0	0	0	0	0	0	0	0	0	0	7,800	3 538

□ Adjust gross vehicle weight & axle loading according to component weight. Note: All weights are ± 3%.

Axle	Max. Load @ 49.7 mph. (80 km/h)
1, 2, 3, 4 and 5	30,865 lbs. (14 000 kg) – steel disc wheels with 20.5R25 tires

Transport Weights and Dimensions – approximate

Two-piece telescoping lattice fly 3,688 lbs. (1 673 kg)

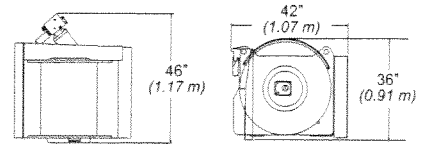
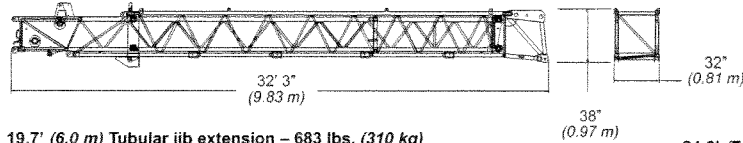

Auxiliary Winch (Rear) with 820' (250 m)
3,176 lbs. (1 441 kg)

19.7' (6.0 m) Tubular jib extension – 683 lbs. (310 kg)

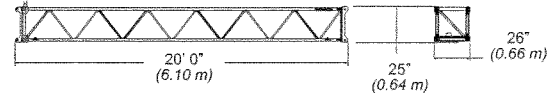

24.6' (7.5 m) Tubular jib extension – 816 lbs. (370 kg)

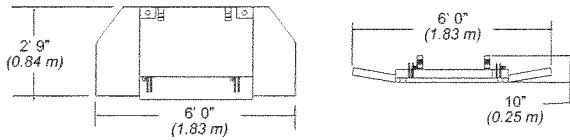
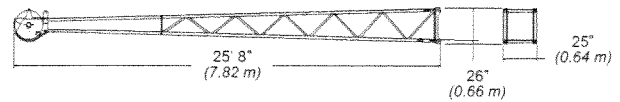

#1 Counterweight – 2,425 lbs. (1 100 kg)

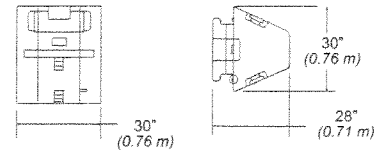

#7 Counterweight (two) – 3,968 lbs. (1 800 kg) – each

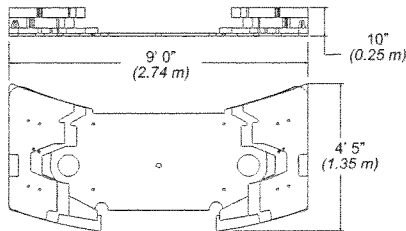

#2, 3, & 4 Counterweights – 5,512 lbs. (2 500 kg)

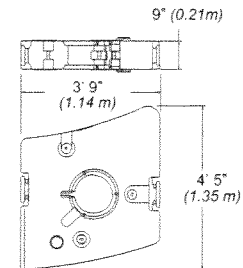

#8 Counterweight (two) –
4,409 lbs. (2 000 kg) – each

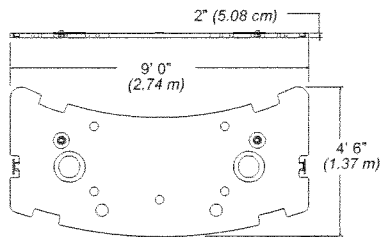

#5 Counterweight – 2,205 lbs. (1 000 kg)

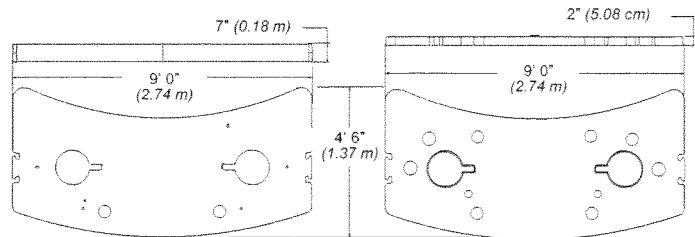

#9 Counterweight – 7,937 lbs. (3 600 kg)

#10 Counterweight – 1,984 lbs. (900 kg)

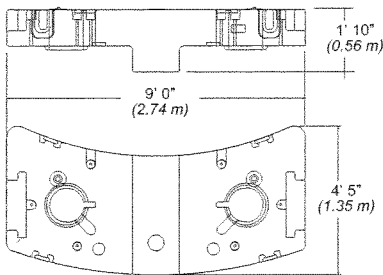

#6 Counterweight – 16,314 lbs. (7 400 kg)

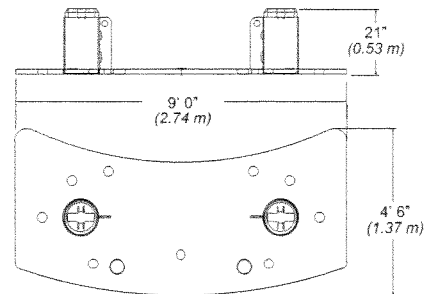

#11 Counterweight – 2,425 lbs. (1 100 kg)